

Features:

- 1" heavy-duty powder coated steel tubing
- Non-marring casters
- Rear wheels roll smoothly over the toughest surface
- Lockable hinged lid
- 28"L x 22"W x 43"H
- Storage Bag
- Black

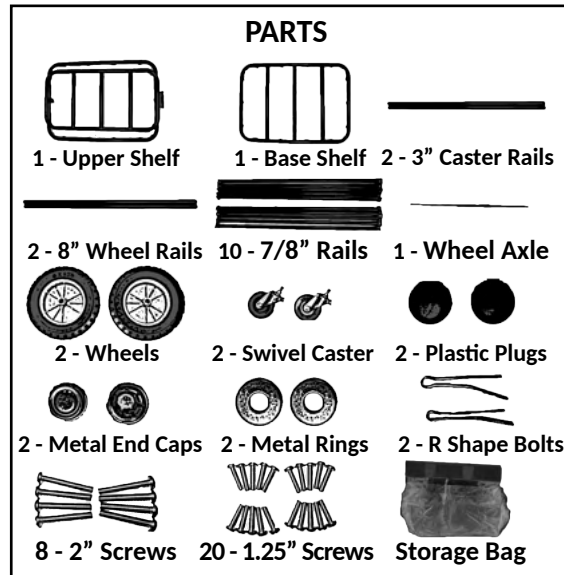

Instructions:

Maximize gym floor space with the Champion Sports Compact Ball Locker.

1. To assemble your Compact Ball Locker securely, please use a mallet or towel covered hammer and a screw driver during assembly. For your safety, please assemble the locker on a spacious flat ground.
2. Attach steel caster rails & wheel rails to upper shelf/base shelf and secure with screws. Figure 1
3. Insert casters into the bottom holes of the steel rail. Figure 2
4. Insert the wheel axle into the lower hole drilled on the wheel rail and put a metal ring, then wheel and R-shape Bolt in that order. Use a mallet to have the end cap attached on the axle. Figure 3
5. Attach all 7/8" steel rails to the upper shelf/base shelf and secure with screws. Figure 4
6. Put the Storage Bag on the ball locker unit. Put the plastic plugs into the rails. Figure 4

Figure 1

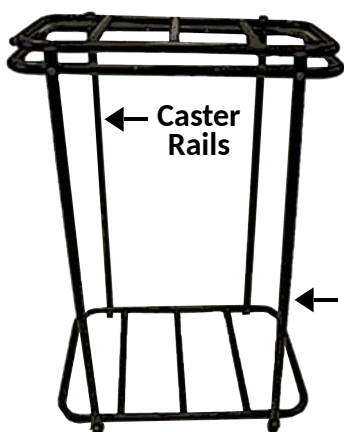

Figure 2

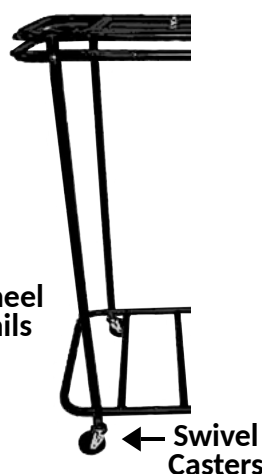

Figure 3

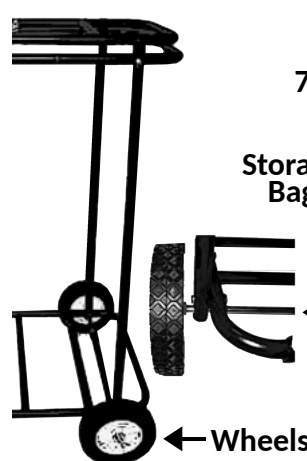

Figure 4

